

Firmenanschrift aufbewahren - Nicht geeignet für Kinder unter 3 Jahren! - Verschluckbare Kleinteile! Keep the address of the company - Not suitable for children under 3 years! - Contains small parts! Veuillez conserver l'adresse - Ne convient pas pour les enfants de moins de trois ans! - Contient de petites pièces pouvant être absorbées! Adres bewaren - Niet geschikt voor kinderen beneden 3 jaar! - Kleine onderdelen kunnen worden ingeslikt!

SOL-EXPERT group, C.Repyk - Mehlistrasse 19 - D-88255 Baidt
 Tel.: +49 (0)7502 - 94115-0 - Fax: +49 (0)7502 - 94115-99
 info@sol-expert-group.de - www.sol-expert-group.de

MADE IN EUROPE



10+



No. 16533

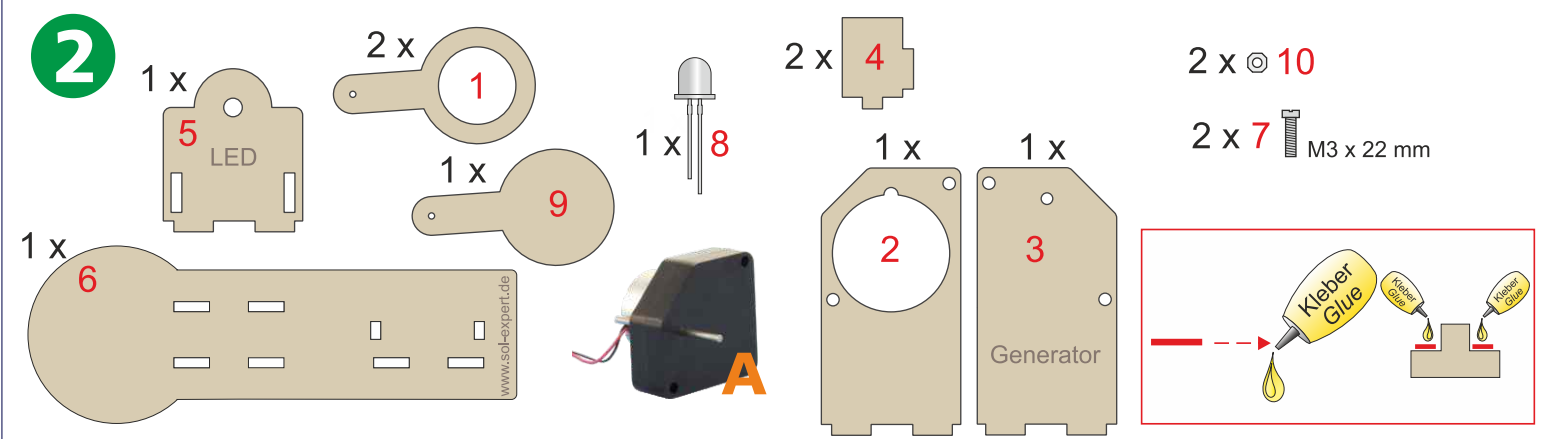
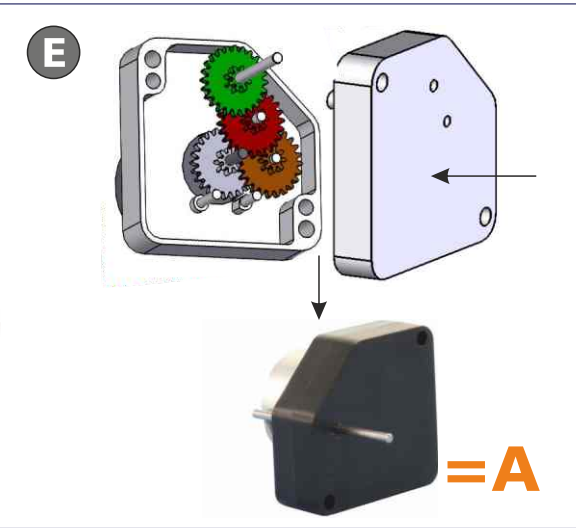
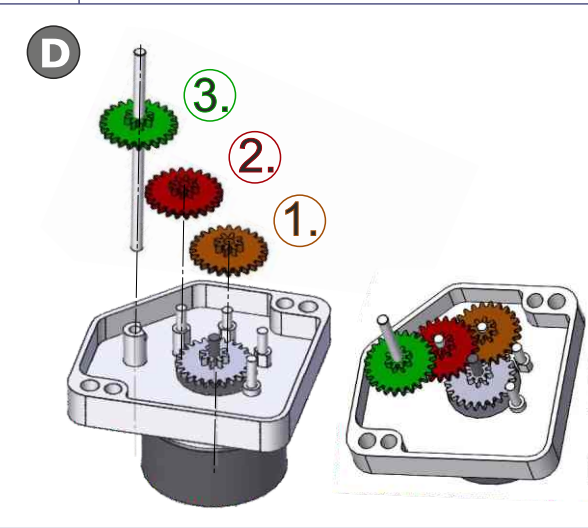
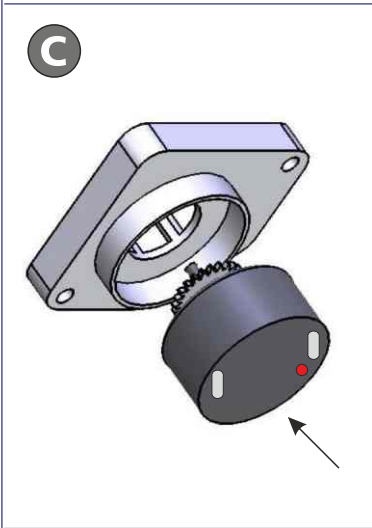
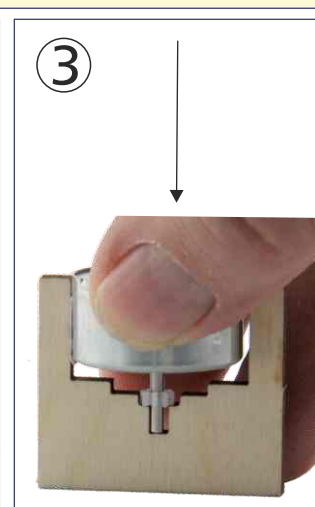
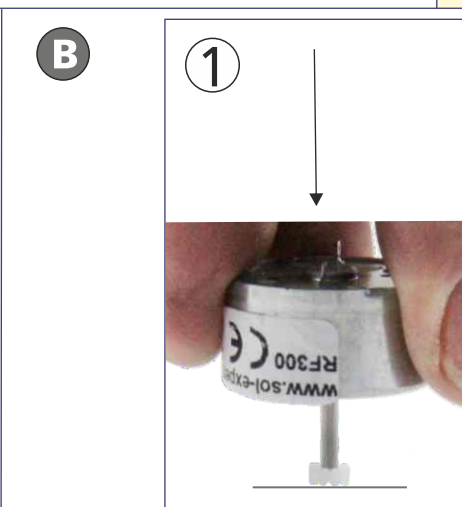
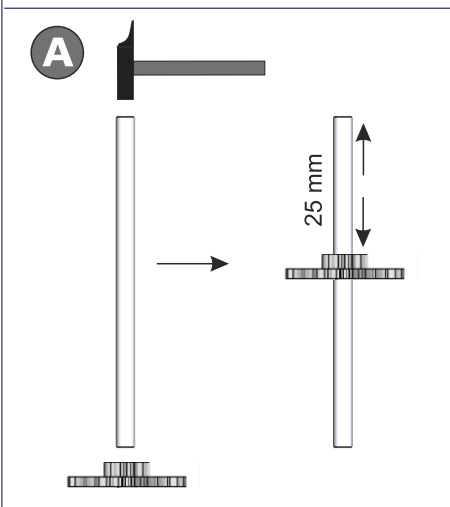

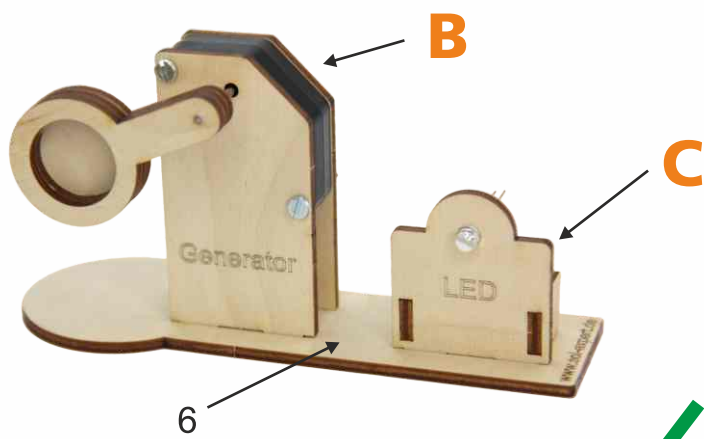
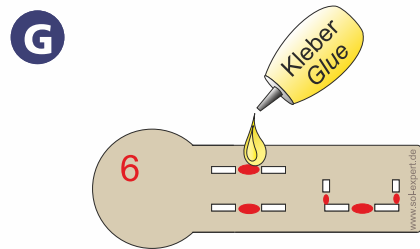
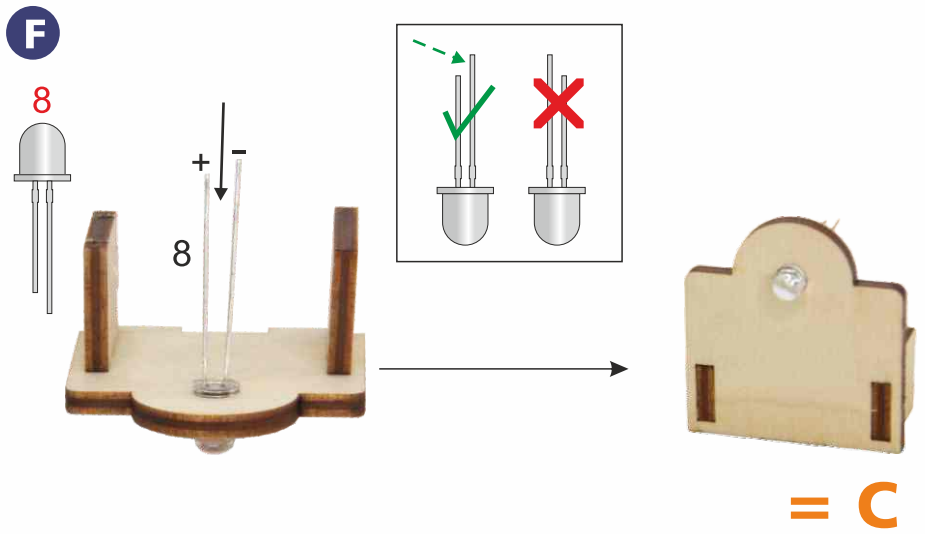
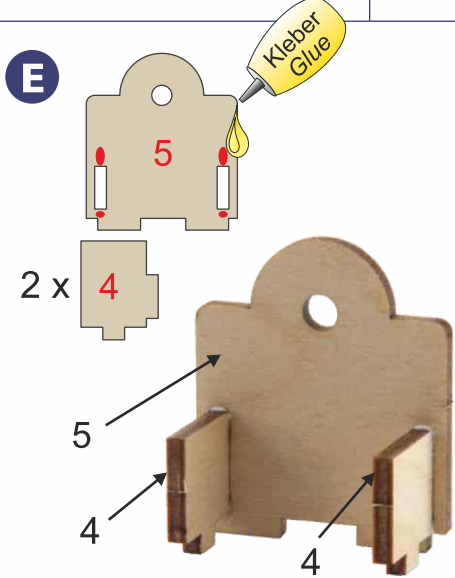
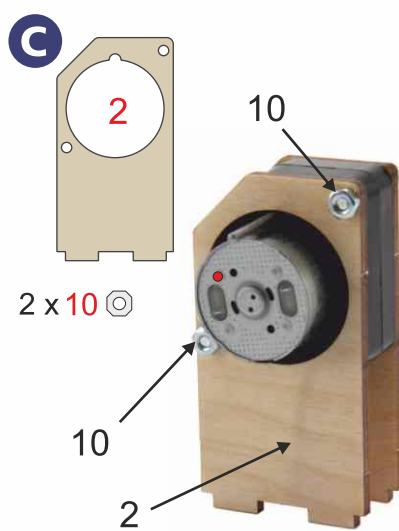
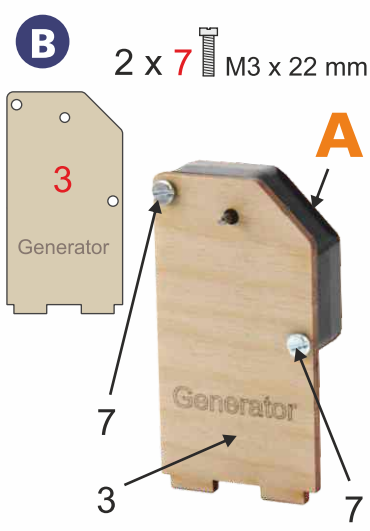
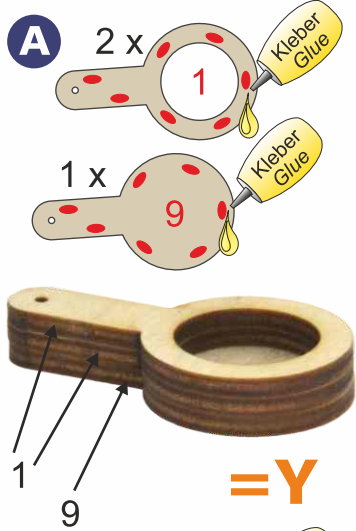

3 EXPERIMENTS

1 Producing electricity with a generator

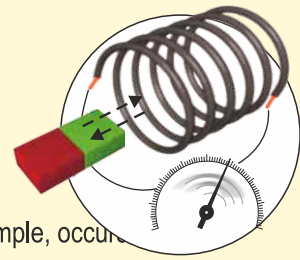

How it works:

A generator converts rotary motion (mechanical energy) into electrical energy. This, for example, occurs when a magnet is moved inside a coil (wire wound several times). The electrical power generated by this movement can e.g. make a **light-emitting diode light up**.

A related experiment:

	<p>Connect the drive and LED using the alligator clips as shown:</p>	<p>1 Now turn the crank in the direction shown, first slowly, then faster and faster, and watch how the LED responds! 2</p>
--	--	---

- Turning the crank handle makes the light-emitting diode light up. This proves electrical power is being produced and can be used by the light-emitting diode.
- The faster the crank handle is being turned, the brighter the light-emitting diode lights up. I.e. the faster the rotation, the more electric power is being generated.

2 One-way street LED



Is it true an LED will only light up if electricity is flowing in the correct direction? Let's try this out:

	<p>Connect the drive and LED using the alligator clips as shown:</p>	<p>1 Now turn the crank in both directions and remember which direction makes the LED light up! 2</p>
	<p>Now switch the location of the cables on the LED, green with red!</p>	<p>3 Now turn the crank in the direction which did not make the LED light up before! 4</p>



Diodes, which includes light-emitting diodes, only allow electricity to flow in one direction. The correct polarity is therefore important when using diodes. LED is an acronym for: "light-emitting diode".

3 Do you need force to generate energy?

We can check this with a simple experiment:



Connect the drive and LED using the alligator clips as shown:

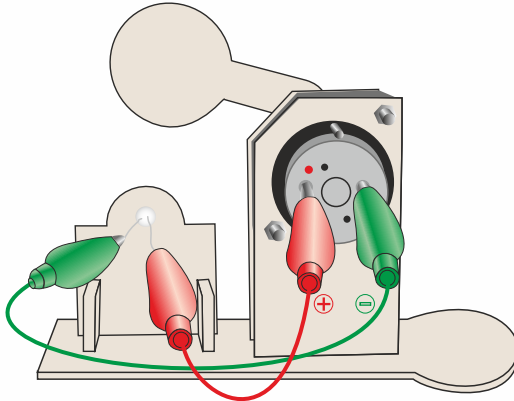

1

Turn the crank in the direction shown at a steady speed and remember how strong you need to turn..

2

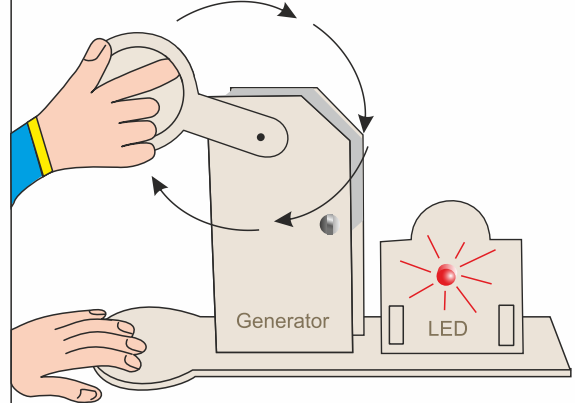

Now remove the red cable from the terminal strip...

3

... and turn the crank at the same speed as before..

4

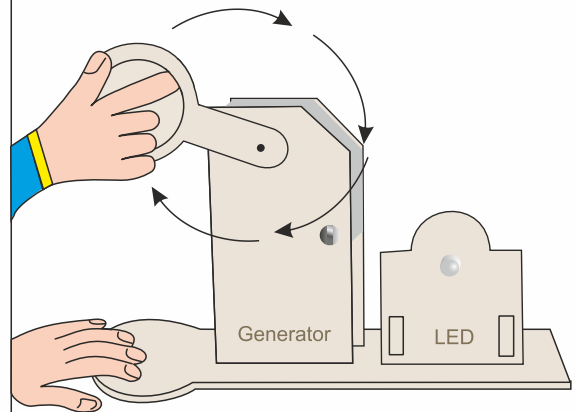
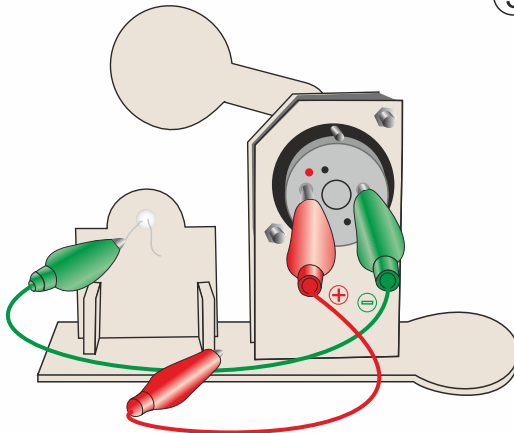

Now add the red cable to the green cable..

5

... and turn the crank at the same speed as before..

6

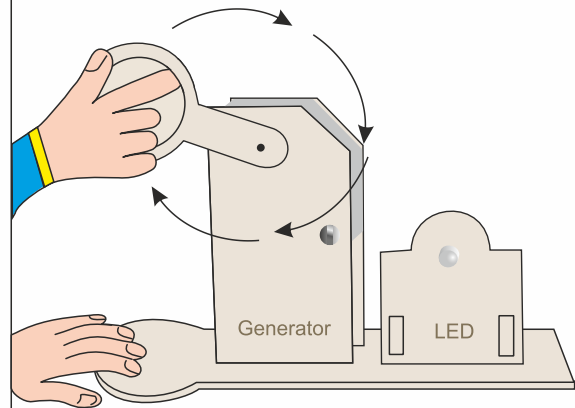
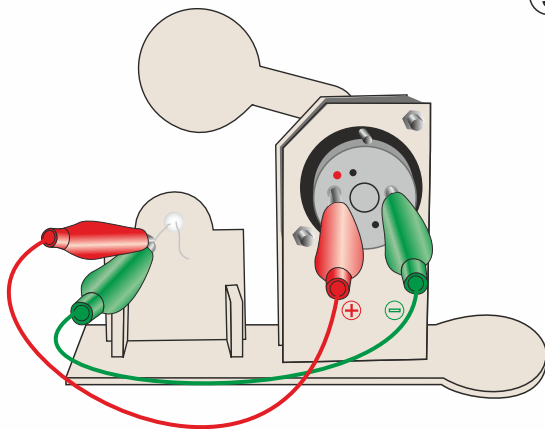

- After connecting a load (in this case the LED) the required cranking power increases. The more energy is being used, the more power you need to supply.
- The maximum exertion of force is generated by a short circuit ("+" and "-" touching).